

ITEM NO.	PART NUMBER	DESCRIPTION	DESCRIPTION 2	QTY
1	XBR30001500202	X-BRACE ASSEMBLY, SERIES 3000	199.86 in	2
2	BMB-037	HARDWARE KIT, CENTER CLAMP	SD	1

PUPI[®]
www.pupicrossarms.com

REVISIONS				
ECO	REV.	DESCRIPTION	DATE	INITIALS
	0.1	PLACE ALL HARDWARE IN KIT	2013-12-27	RAF
	0.2	UPDATE DRAWING FORMAT	2015-12-22	RAF

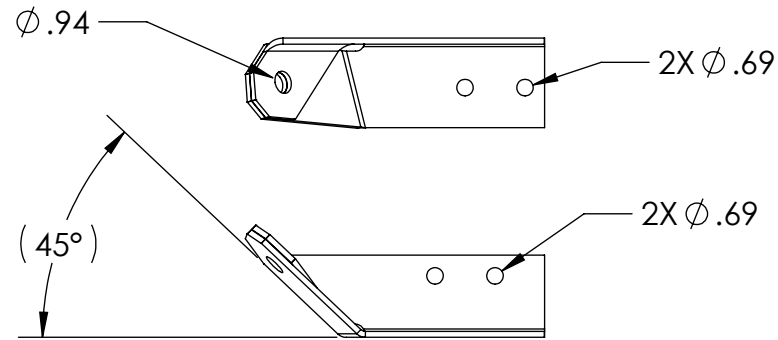

DETAIL -A-
SCALE 1:8

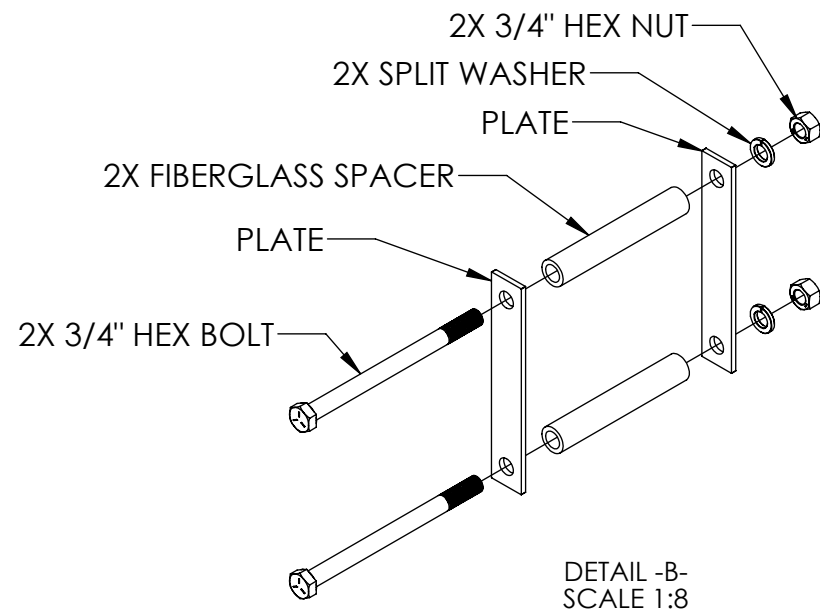

DETAIL -B-
SCALE 1:8

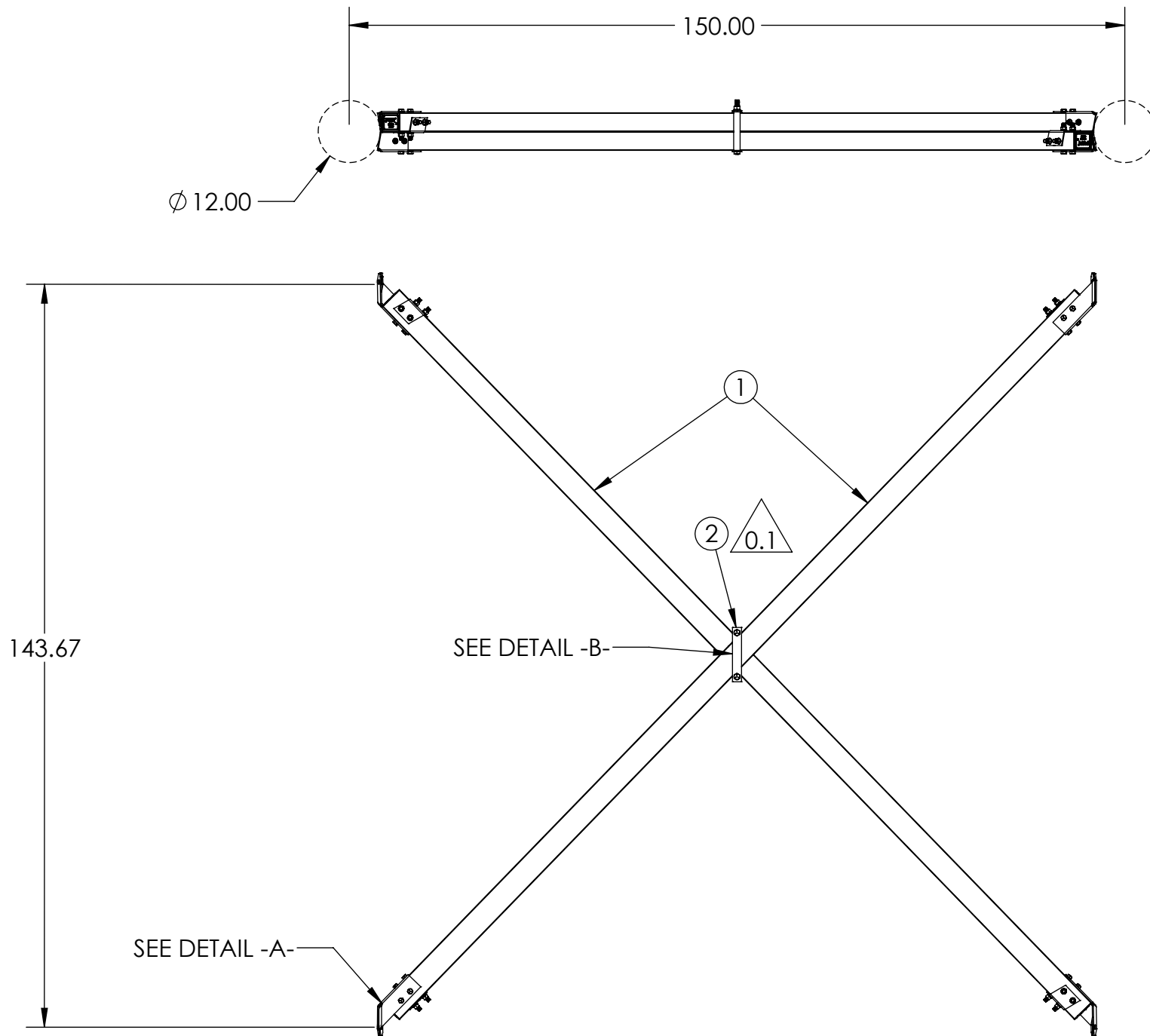

NOTES:

- X-BRACE IS DESIGN WITH 12 INCH DIAMETER STRAIGHT POLES
- 7/8" HARDWARE TO FASTEN X-BRACE TO POLES **NOT SUPPLIED BY GEOTEK**
- HARDWARE KIT BMB-037 SHIP SEPARATELY
- BRACKETS GALVANIZED IN ACCORDANCE WITH ASTM A123/A123M OR ASTM A153/A153M
- HARDWARE GALVANIZED PER ASTM A153/A153M OR ASTM F2329

---UNLESS OTHERWISE SPECIFIED---

DIMENSIONS ARE IN INCHES
INTERPRET DIM AND TOL PER ASME Y14.5-2009
ANGULAR: MACH ±2°
BEND ±2°
ONE PLACE DECIMAL ±0.1
TWO PLACE DECIMAL ±0.02

STATE:	RELEASED	2016-01-06
DRAWN:	RAF	2013-05-07
CHECKED:	TRB	2016-01-06
APPROVED:	TRB	2016-01-06
REPLACES:		

PROPRIETARY AND CONFIDENTIAL
THE INFORMATION CONTAINED IN THIS DRAWING IS THE SOLE PROPERTY OF GEOTEK. ANY REPRODUCTION IN PART OR AS A WHOLE WITHOUT THE WRITTEN PERMISSION OF GEOTEK IS PROHIBITED.

THIRD ANGLE PROJECTION

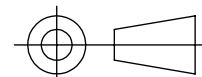

CUSTOMER SIGNATURE:

DATE:



1421 SECOND AVE NW
STEWARTVILLE, MN 55976
(800) 533-1680
www.geotekinc.com

DESCRIPTION:
X-BRACE SYSTEM, SERIES 3000
150 in



SIZE: DWG. NO.
B XBR30201500342

BEAM COLOR: REV:
GRAY 0.2

SCALE: 1:28 | WEIGHT: 185 LBS

SHEET 1 OF 1